



Preliminary evaluation of cavitation resistance of type 316LN stainless steel in mercury using a vibratory horn

S.J. Pawel ^{*}, E.T. Manneschmidt

Metals and Ceramics Division, Oak Ridge National Laboratory, P.O. Box 2008, Oak Ridge, TN 37831-6156, USA

Abstract

Type 316LN stainless steel in a variety of conditions (annealed, cold-worked, surface-modified) was exposed to cavitation conditions in stagnant mercury using a vibratory horn. The test conditions included peak-to-peak displacement of the specimen surface of 25 μm at a frequency of 20 kHz and a mercury temperature in the range -5 to 80 $^{\circ}\text{C}$. Following a brief incubation period in which little or no damage was observed, specimens of annealed 316LN exhibited increasing weight loss and surface roughening with increasing exposure times. Examination of test surfaces with the scanning electron microscope revealed primarily general/uniform wastage in all cases but, for long exposure times, a few randomly oriented ‘pits’ were also observed. Type 316LN that was 50% cold-worked was considerably more resistant to cavitation erosion damage than annealed material, but the surface modifications (CrN coating, metallic glass coating, laser treatment to form a diamond-like surface) provided little or no protection for the substrate. In addition, the cavitation erosion resistance of other materials – Inconel 718, Nitronic 60, and Stellite 3 – was also compared with that of 316LN for identical screening test conditions.

Published by Elsevier Science B.V.

1. Introduction

The spallation neutron source (SNS) will generate neutrons via interaction of a pulsed 1.0 GeV proton beam with a liquid mercury target. The duration of each proton pulse will be short ($<1 \mu\text{s}$) and the temperature rise of the affected volume during each pulse will be small (5–10 $^{\circ}\text{C}$), but the extreme heating rate is expected to give rise to a thermal-shock induced pressure wave, which then travels into the surrounding Hg. When the compression wave reaches a boundary (e.g., the container wall), it will be reflected back with a change of phase. The resulting rarefaction wave travels back into/through the Hg, exposing the Hg to transient negative pressures. At a sufficient negative pressure, microscopic bubbles are expected to form in the Hg. Previous research [1,2] indicates less than 1 MPa is required to generate bubbles in Hg of nominal purity at SNS. When

the bubbles collapse (in principle, with each pulse cycle) at/near the containment surface, some of the energy released – typically a ‘jetting’ action of liquid at extreme velocity – can effectively erode the surface through a scrubbing action. Calculations [3] for SNS operating conditions suggest that negative pressures sufficient to induce cavitation will be routinely present in the target near the beam window, and therefore cavitation erosion potentially could be a localized wastage issue for the SNS target container.

Some recent experiments [4] have indicated that pressure pulses in Hg appear capable of causing pitting damage in stainless steel containers. For example, experiments in which stainless steel surfaces in contact with Hg were subjected to mechanically-induced pressure pulses via the Split-Hopkinson Pressure Bar (SHPB) technique generated shallow pits on the container walls [5]. Subsequently, cylindrical Hg-filled containers with flat ends were irradiated with 200 pulses of 800 MeV protons at SNS-relevant beam intensities. Experiments are still ongoing [4], but the presence of pits on the flange ends of the containers was confirmed for several combinations of materials and surface treatments. The

^{*} Corresponding author. Tel.: +1-865 574 5138; fax: +1-865 241 0215.

E-mail address: pawelsj@ornl.gov (S.J. Pawel).

individual pits/clusters had various diameters and were generally on the order of 20 μm deep. Even though no relation between the number of pulses and pitting damage has been established, cavitation erosion damage appears to be a potential issue for the mercury target containment given the design life expectation of perhaps 6–7 orders of magnitude more pulses for the SNS target than experienced by either the SHPB or in-beam exposures.

Experiments with a vibratory horn have been initiated in order to screen and compare materials/treatments prior to additional in-beam cavitation tests. Although there is no specific correlation between the damage intensity/rate produced at the surface of a specimen in the vibratory horn and potential cavitation erosion damage in the SNS mercury target containment resulting from proton pulses, the cavitation erosion resistance of 316LN (prime candidate target container material) can be readily compared with that of other engineering materials in this type of test.

2. Experimental

Cavitation erosion tests were performed using a titanium vibratory horn (shown in Fig. 1) and the general methodology described in ASTM G-32 [6]. The unit oscillated at a fixed frequency of 20 kHz and was set to generate a peak-to-peak vibrational amplitude of approximately 25 μm . The rapid reciprocating displacement of the specimen surface induces the formation and collapse of cavities in the liquid near the specimen surface, and cavitation erosion damage from collapsing bubbles can be quantified by measurement of weight loss and/or penetration depth as a function of exposure time. A jacketed stainless steel container holding about one liter of high purity Hg permitted temperature control for each test by circulating a water/ethylene glycol mixture from a constant temperature bath via insulated tubing. Most tests were performed at a mercury temperature of 25 °C but a limited number of tests were also performed

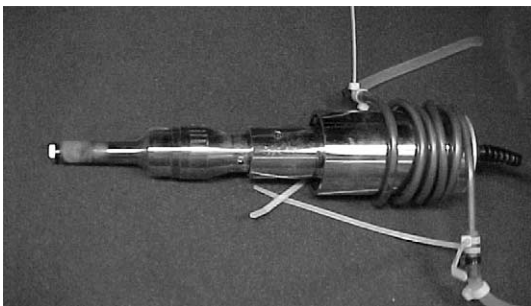

Fig. 1. Vibratory horn unit. A specimen is loosely placed on the tip at left, and the copper tubing at right forms a cooling coil to limit overheating of the piezoelectric crystal.

at –5 and 80 °C. Test temperature was measured with thermocouples in the Hg – one placed about 1.5 cm below the test surface and another placed near the container ID at the depth of the test specimen. The precise temperature of the test surface, if different from the local Hg temperature, is not known. Temperature control was required for all tests (even brief ones) because the cavitation medium is rapidly heated by the energy input of the sonication process. In all cases, the specimen surface was immersed 25 mm below the surface of the Hg in the center of the container, which was open to room air. The crystal case of the vibratory horn was wrapped with a water-cooled copper coil to reduce over-heating of the piezoelectric crystal, which nevertheless occasionally halted operation of the unit during a test.

Test specimens were prepared using ASTM G-32 as a guide and a schematic example is shown in Fig. 2. The diameter of the horn was 15.9 mm, so the diameter of the button test surface was chosen to match this value. The shank of each specimen was 10 mm in length with a 2.5 mm diameter bore in the center to reduce the mass of the specimens. The head thickness of each type 316LN stainless steel button (the ‘h’ dimension in Fig. 2) was 3.56 mm (0.140 in.). For buttons of other materials, the ‘h’ dimension was adjusted slightly to account for different densities in order to maintain constant specimen mass (8.00 ± 0.05 g). The head of each specimen had

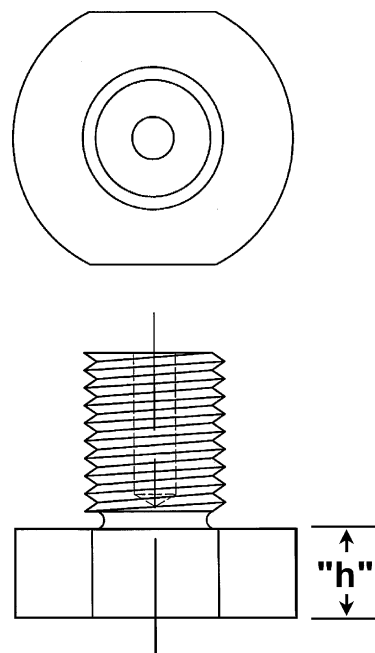

Fig. 2. Schematic drawing of a vibratory horn specimen. The ‘h’ dimension was varied slightly as a function of material to account for different density while keeping the specimen mass constant.

small flats machined to facilitate tightening (and removing) the specimen in the horn tip.

The reference material for the SNS target container is 316LN stainless steel. Buttons were machined from mill-annealed material, the test surface polished on 600 grit paper, and then the specimens were vacuum annealed for 0.5 h at 1020 °C. Identical specimens were also prepared from the same heat of 316LN except that the plate stock was cold rolled 50% prior to machining and polishing. Four surface modifications of the annealed 316LN material were also evaluated in limited testing:

- annealed 316LN was tested in the as-machined condition, which left a 'skin' of disturbed metal and significant surface relief (lathe rings) on the test face;
- annealed 316LN in the as-machined condition was treated to develop approximately a 10 µm layer of CrN;
- annealed 316LN in the as-machined condition was coated with a proprietary metallic glass to a thickness of approximately 200 µm; and
- annealed and polished (0.25 µm) 316LN was treated with lasers to convert the near surface (2 µm) material to a diamond-like coating.

In addition to 316LN stainless steel, three other materials (all compositions given in Table 1) were included in the test matrix. Inconel 718 has been considered an alternate target container material [7] and has been used successfully in target window applications. Nitronic 60 is an austenitic stainless steel with somewhat similar composition to 316LN but a high work hardening rate deemed significant to cavitation erosion resistance [8]. Stellite 3 is a cobalt-based alloy known for high hardness and significant resistance to cavitation erosion. These materials were tested in the following conditions:

- Inconel 718, 600 grit polished and annealed 0.5 h at 1050 °C;
- Inconel 718, aged (air cooled from 954 °C to 718 °C, 8 h hold, furnace cooled to 621 °C, 8 h hold, air cool to ambient) and 600 grit polished;
- Nitronic 60, 600 grit polished and annealed 0.5 h at 1020 °C;
- Nitronic 60, 25% cold-worked and 600 grit polished; and
- Stellite 3, as-cast condition, 600 grit polish.

For most exposures, a virgin coupon (no previous exposure) was cleaned and weighed, tested for a specific duration, then cleaned and reweighed to determine the extent of erosion damage. In a few instances, specimens with previous exposure histories were tested further to accumulate a larger cumulative exposure time. Considering the slight scatter in weight loss data for duplicate test conditions, the results suggest that long, uninter-

Table 1
Composition (wt%) of alloys

Element	316LN	Inconel 718	Nitronic 60	Stellite 3
C	0.009	0.031	0.067	2.4
Mn	1.75		8.29	<1
P	0.029	0.006	0.031	
S	0.002	0.0004	0.001	
Si	0.39	0.10	4.31	<1
Ni	10.2	balance	8.34	<3
Cr	16.31	17.83	16.56	31
Mo	2.07	2.87	0.27	
Co	0.16			balance
Cu	0.23		0.40	
N	0.11	0.0037	0.14	
Fe	balance	19.38	balance	<3
Ta + Nb		5.06		
Ti		0.92		
Al		0.63		
B		0.004		<1
W				12.5

Compositions from certified mill reports except for Stellite 3, for which a nominal composition is given.

rupted exposures and a number of short exposures summing to the same total sonication time yield very similar results.

3. Results and discussion

3.1. Data interpretation

The evaluation attempted here was considered to be only a screening test because the conditions imposed are not specifically prototypic to conditions expected near the SNS target window. Generally speaking, the vibratory horn imposes considerably higher pressure pulse frequency but at a much lower pressure/intensity than expected in the actual SNS target. Frequency and amplitude relevance to SNS aside, however, and additional subtle difference between these experiments and cavitation in the SNS target is that the target surfaces will receive pressure pulses generated at remote locations in the Hg. In the vibratory horn experiments, the test surfaces themselves are used to create the pressure pulses.

Following each cavitation test, complete and tenacious wetting of the specimen by Hg was observed in as little as two minutes of sonication. Following each test, dewetting in room air was routinely observed over a period of several hours. Final clean-up was accomplished with a brief ultrasonic treatment in an aqueous sulfur-containing bath that chemically binds Hg, followed by rinsing in water, ultrasonic treatment in acetone, and forced air drying.

During the period in which the specimens were wetted by the Hg, it is possible that a corrosion/dissolution

contribution to the cavitation erosion weight loss could occur. However, a corrosion component of weight loss in these relatively brief exposures was deemed unlikely for several reasons:

- Hg thermal convection loop experiments in support of the SNS materials program [9–11] involved many of the alloys/conditions tested here and found little or no dissolution in Hg at temperatures up to 305 °C and exposure times to 5000 h.
- Energy-dispersive X-ray analysis of stainless steel surfaces exposed to cavitation conditions in Hg [12] revealed extensive wetting but no interaction of the Hg with the surface (e.g., no composition gradients).
- Examination of components exposed in Hg during testing but not to sonication conditions yielded no evidence of surface changes or corrosion [13].

Clearly, any regions suffering from corrosion in Hg might be particularly prone to erosion and be rapidly removed from the specimen surface by the sonication process. One way to potentially separate these effects would be to perform pulsed tests in which the sonication process is periodically interrupted while exposure to Hg continues, and compare results to exposures with no pulsing. However, even this type of test does not account for the fact that temperature and pressure can be quite high locally during the sonication process. Ultimately, then, the relative resistance to cavitation in this screening test was judged based on the total weight loss and surface changes without an attempt to separate components due to erosion versus simple dissolution in Hg.

In the strictest sense, cavitation erosion should perhaps be evaluated based on mean depth of penetration (weight loss divided by specimen area and density) that describes the extent of attack and which permits com-

parison of materials with different densities. However, caution must be exercised with this data as well, as it implies a uniform wastage over the specimen surface that is not always the case. Where it is possible or practical, both values will be used throughout the discussion that follows.

3.2. Type 316LN stainless steel

Fig. 3 compares cavitation erosion data collected for 316LN in the polished/annealed condition with data for 316LN in the 50% cold-worked/polished condition. The plot of weight loss versus exposure time at 25 °C reveals that after an incubation period, the annealed material is significantly more susceptible to cavitation erosion damage than the 50% cold-worked specimens. An incubation period seems consistent with the concept that cavitation erosion advances by a fatigue type of behavior in which micro-cracks must be initiated and coalesce/propagate to effect material loss under the bombardment of shock waves and erosion resulting from collapsing bubbles [8]. The difference in hardness of the annealed 316LN (HRB 55–60) compared to the 50% cold-worked 316LN (HRC 30–35) probably accounts for the superior cavitation erosion resistance of the latter material.

Previously, Garcia et al. [13] also tested annealed 316 stainless steel under similar cavitation conditions using a vibratory horn. They used 20 kHz with 50 μm displacement at 21 °C and measured a weight loss of 9.9 mg/h (corresponds to 8.4 $\mu\text{m}/\text{h}$), which compares with an average weight loss of 7.7 mg/h (5.3 $\mu\text{m}/\text{h}$) for annealed 316LN in the present investigation at 25 °C and 25 μm displacement. This result suggests that an increase in the cavitation intensity described by an increase in the displacement by a factor of two corresponds to an increase in cavitation erosion by about 30%

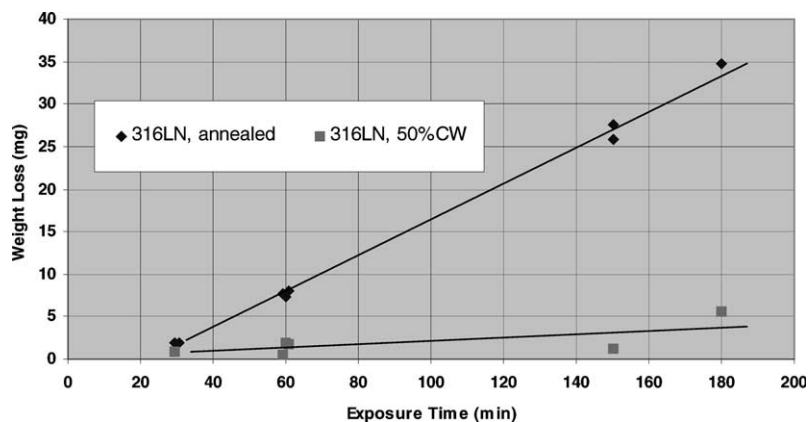

Fig. 3. Specimen weight loss vs. exposure time for cavitation erosion of 316LN in Hg at 25 °C. Trend lines are included for ease of presentation.

in Hg. Kass et al. [14] also studied cavitation of annealed 316 in Hg under various conditions. In Hg at about 42 °C, they found cavitation erosion rates of about 12 $\mu\text{m}/\text{h}$ after 2 h exposure at a displacement of 21 μm , with cavitation erosion increasing by a factor of about two when the displacement was increased to 47 μm . Significantly higher damage rates were observed for a displacement of 74 μm . Further, Garcia et al. [13] found the weight loss rate for annealed 316 in Hg at 21 °C and 50 μm displacement to remain approximately constant to at least 12 h exposure. Taken together, these results are quite consistent with the present data for annealed 316LN in Hg.

Fig. 4 shows representative specimen surfaces of annealed 316LN following cavitation testing at 25 °C. Note that the surface of the specimen exposed for 30 min appears to have very shallow, uniform wastage. However, the specimen exposed for a longer period appears to have some ‘pits’ scattered on the surface that are significantly larger/deeper than the average damage. This pattern of behavior was also observed by Young and Johnston [15], who noted that damage in some

liquid metals (e.g., Na) tends toward general attrition while damage in Hg tends toward formation and deepening of craters. Fig. 5 shows SEM micrographs of a pitted area on the specimen exposed 150 min. It shows that pits/craters have begun to form irregularly over the specimen surface. The deepest craters shown here are at least 150 μm deep.

The 50% cold-worked 316LN was found to be much more resistant to cavitation erosion than the annealed counterpart. Fig. 6 shows SEM micrographs of the

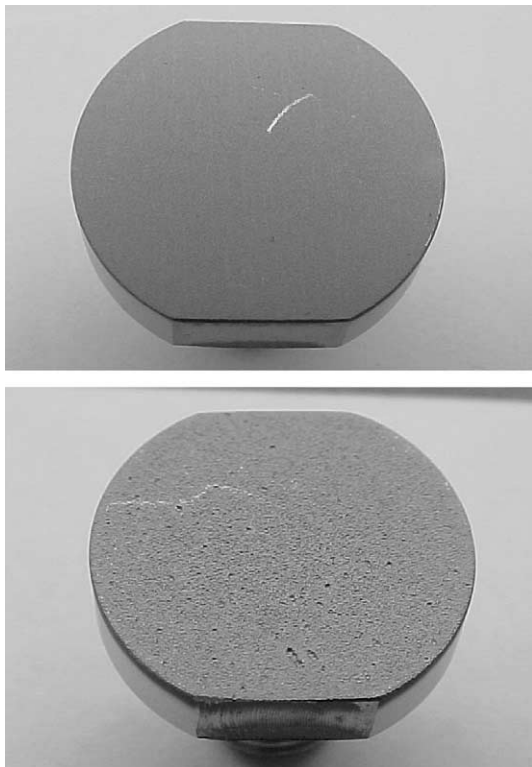

Fig. 4. Annealed 316LN specimen exposed to cavitation conditions in Hg at 25 °C for 30 min (top) and 150 min (bottom). The scratch on the specimen exposed 30 min was made with a light scrape with sharp tweezers to show the shallow nature of attack.

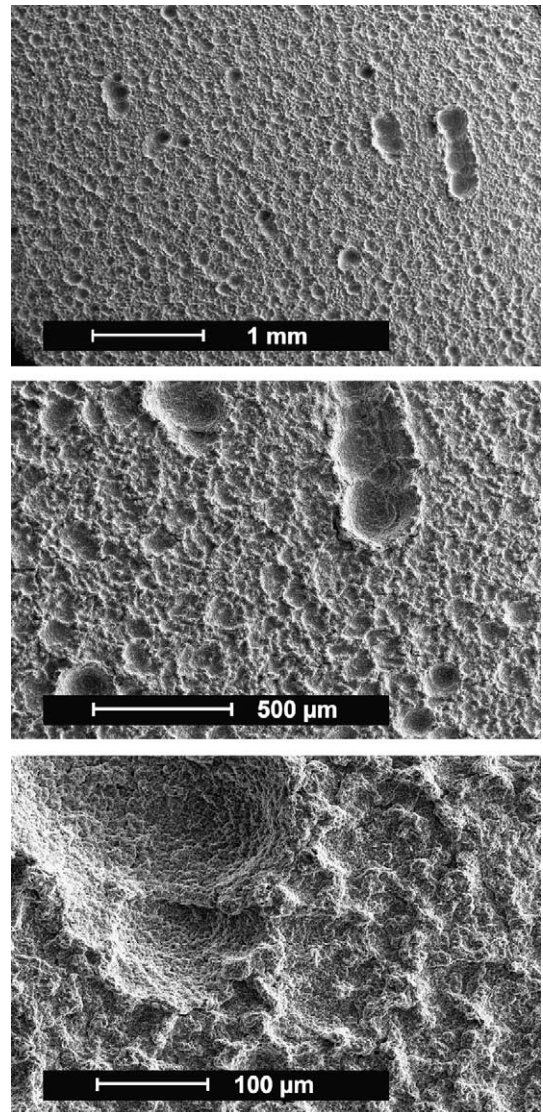

Fig. 5. Scanning electron micrographs of the surface of annealed 316LN after sonication for 150 min in Hg at 25 °C. All micrographs are from the area near the row of pits readily visible in the lower portion of the corresponding photo in Fig. 4.

specimen surface following 3 h sonication in Hg at 25 °C. While the surface was generally observed to be only lightly roughened (compare to Fig. 5), 3–4 small craters were observed on the surface. The crater shown here is only about 30 μm deep.

Among the original specimens examined were some 316LN buttons machined from mill-annealed stock. These buttons were tested in the as-machined condition and, as such, the surface was slightly disturbed/worked by the machining process. For exposures of 30 and 60 min at 25 °C, these specimens behaved very similarly to the 50% cold-worked specimens, but for longer exposures, the mass loss was identical to that of the polished and annealed material. This result suggests that the 'skin' of worked material was sufficiently hard to provide at least short-term erosion resistance. During exposure to cavitation conditions, however, the cold-worked layer was eventually compromised/removed leaving annealed substrate material exposed to the Hg. Fig. 7 shows a series of SEM micrographs of an annealed but as-machined 316LN specimen subjected to cavitation erosion at 25 °C. Note that the surface roughness resulting from cavitation is relatively uniform over the surface and the roughening pattern is not particularly

disturbed by the presence of the lathe rings on the surface. The crater that is shown covers the space between 5 or 6 of the machining rings and appears to have obliterated evidence of the presence of rings. Further, the edges of the crater seem to be slightly raised compared to the surrounding topography, suggesting a particularly violent 'impact' event, while the bottom of the crater appears similar to the surrounding topography.

A limited number of tests were also performed for annealed 316LN with other surface modifications. Specimens of 316LN with about 10 μm of CrN on the annealed but as-machined surface lost the entire weight gain due to the coating – plus a small additional amount – in the first 60 min of exposure at 25 °C. Similar to 50% cold-worked 316LN, subsequent weight losses were small (about 1 mg in 30 min) during additional exposures

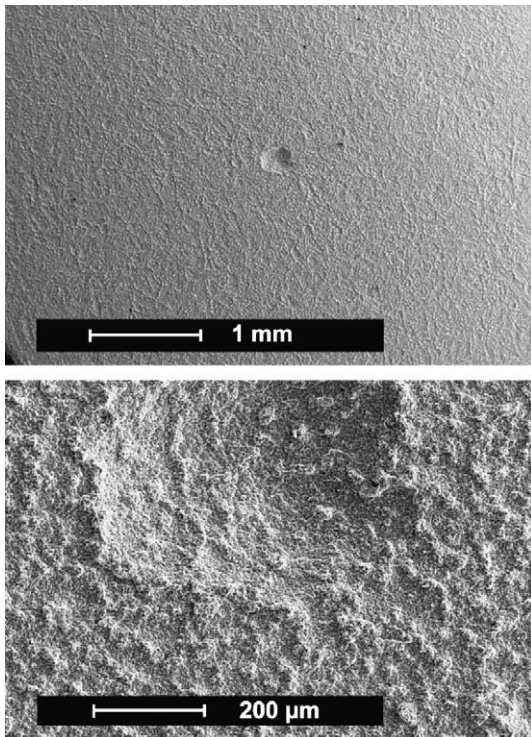

Fig. 6. Scanning electron micrographs of the surface of 50% cold-worked 316LN subjected to sonication in Hg for 3 h at 25 °C. These photos are not particularly representative of the surface as there were only 3–4 pits this size on the entire specimen.

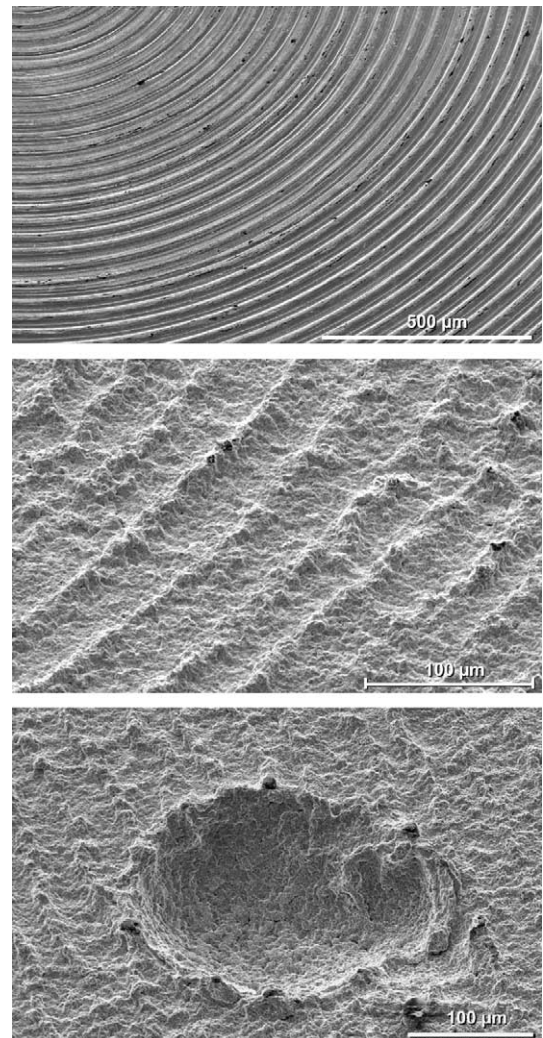

Fig. 7. Scanning electron micrographs showing an annealed but as-machined 316LN specimen (a) unexposed, at top, and (b) exposed 120 min in Hg at 25 °C.



Fig. 8. LN specimen with metallic glass coating that has partially failed near the near edge.

up to 120 min cumulative time. However, longer exposures yielded relatively high weight loss similar in magnitude (about 3.6 mg in 30 min) and appearance to that observed for polished and annealed 316LN. These results suggest that the initial CrN layer was not sufficiently well bonded to the substrate to survive the initial sonication period. However, sufficient residual stress in the substrate lattice near the surface apparently provided hardening sufficient to generate short-term resistance to cavitation erosion.

Weight loss as a result of cavitation erosion is somewhat more difficult to interpret for annealed, as-machined specimens of 316LN with about 200 μm of metallic glass coating plasma sprayed onto the surface. The coating appears to provide a relatively hard and cavitation resistant surface that protects the substrate from erosion damage, but the coating is sufficiently brittle that chunks were prone to become dislodged (see Fig. 8). A similar coating 'failure' was also observed over a small area as a result of simple handling of the speci-

men (torque specimen into place with a wrench). An attempt to duplicate this result did not generate an obvious failure but did result in a weight loss corresponding to over 70 mg/h, indicating that the coating is subject to high cavitation erosion rates.

A specimen of 316LN in the annealed and machined condition was polished and subjected to a room temperature laser treatment that converts carbon in the substrate to a diamond-like material. In this case, the treatment was performed such that a conversion layer about 10 μm deep was developed. One exposure period of 60 min in Hg at 25 $^{\circ}\text{C}$ was sufficient to destroy the coating and generate a mass loss and appearance identical to untreated/annealed base material.

Literature is available [15] suggesting that the cavitation erosion rate of materials in Hg is temperature sensitive, with maximum erosion near -5 or 0 $^{\circ}\text{C}$ and decidedly decreasing erosion at higher temperatures (up to at least 100 $^{\circ}\text{C}$). To examine that possibility for the present test conditions, 60 min exposures were performed at -5 and 80 $^{\circ}\text{C}$ to complement data collected at 25 $^{\circ}\text{C}$. Fig. 9 shows the weight loss data collected for annealed and 50% cold-worked 316LN and, in contrast to the literature data [15], it indicates cavitation erosion tends to increase with temperature from -5 $^{\circ}\text{C}$ up to 80 $^{\circ}\text{C}$. It is not a particularly strong effect over the indicated temperature range – the increase was a factor of nearly two – but it is noteworthy that the Hg temperature at the outlet of the target window is expected to be 120–130 $^{\circ}\text{C}$.

Garcia et al. [13] also reported cavitation erosion data for annealed 316 stainless steel in Hg at 260 $^{\circ}\text{C}$. Their data was collected for a displacement amplitude of 50 μm (rather than 25 μm in the present case), and they also found an increase in cavitation erosion damage of a factor of two between 21 and 260 $^{\circ}\text{C}$.

In order to provide potential comparison with the large body of literature data for cavitation damage in water, limited data for annealed 316LN stainless steel

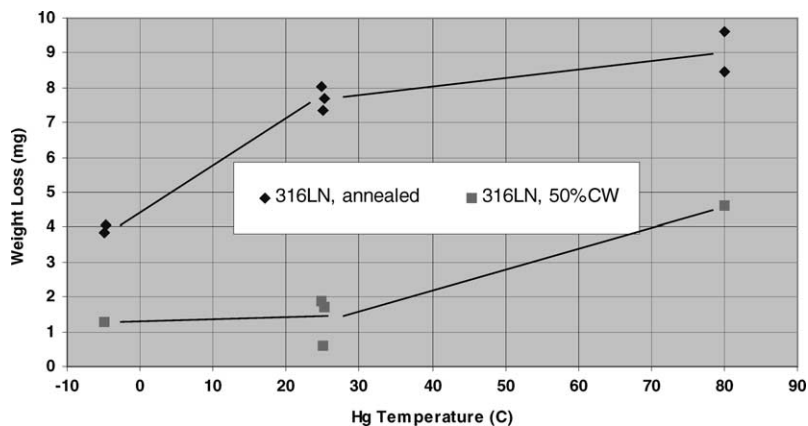

Fig. 9. Specimen weight loss vs. exposure temperature for 60 min cavitation tests in Hg at 25 $^{\circ}\text{C}$. Trend curves are included for ease of presentation.

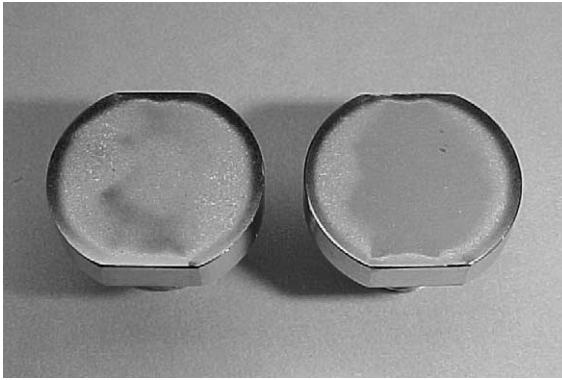

Fig. 10. Annealed 316LN exposed to cavitation conditions in distilled water at 25 °C for 60 min (left) and 180 min (right).

were also collected in distilled water at 25 °C (with all other test conditions identical to the Hg tests). For a single 60 min exposure, weight loss was very low – about 0.21 mg/h, or 0.15 $\mu\text{m}/\text{h}$ – but the single 180 min exposure produced significantly more damage – about 3.5 mg/h, or 2.4 $\mu\text{m}/\text{h}$. These results suggest that Hg is about an order of magnitude more aggressive toward annealed 316LN than is water. The present values compare favorably with that of Garcia et al. [13], who reported a value for annealed 316 in water at 21 °C of 2.8 mg/h (about 2.0 $\mu\text{m}/\text{h}$) for a displacement amplitude of 50 μm . Note that in the case of water, increased displacement amplitude did not correspond to increased cavitation damage. Similarly, Garcia et al. [13] reported a general trend that cavitation in Hg was approximately 3 times more aggressive in Hg than in water. Kass et al. [14] also found Hg to be more aggressive but only at longer exposure times.

Fig. 10 shows specimens of annealed 316LN subjected to cavitation in water at 25 °C from the present experiments. Note that the damage is light and less uniform across the button surface; in particular, the extreme edges of the button appear unattacked. Be-

havior of this type has been observed in other media less dense than Hg, such as Na [15]. It is thought that the different behavior results from complex fluid flows and variations in media density and surface tension.

3.3. Other materials

Previously described specimens of Inconel 718, Nitronic 60, and Stellite 3 were exposed to cavitation erosion tests identical to those for 316LN materials. A 60-min exposure for a virgin coupon was accomplished at each of –5, 25, and 80 °C and another coupon was exposed for a series of three 60-min exposures at 25 °C.

Table 2 summarizes the results of tests at 25 °C for the alternate materials and compares them with data for 316LN. The results indicate that for each material, the specimen in the harder condition suffers less cavitation erosion than its annealed (soft) counterpart. However, hardness is not a stand-alone indicator of cavitation erosion resistance – as measured by weight loss or average penetration – when the different materials are considered. Note that the hardest materials do not necessarily have the best resistance, and in that regard, Stellite 3 was particularly enigmatic. It was – by a significant amount – the hardest material examined but yielded the highest weight losses at 25 °C. Curiously, the post-test appearance of the Stellite specimens was significantly different than that for the other materials. Fig. 11 shows that the sonicated specimen appears to be etched rather than abraded like the other materials. Young and Johnston [15] also observed cavitation erosion attack on Stellite 6B in Hg to be somewhat non-uniform, with the carbides unattacked but the relatively softer matrix appearing somewhat etched. Extended exposures of Stellite 3 at 25 °C yielded significantly reduced weight loss rates but more data and analysis are required to determine the mechanism of this behavior.

Generally, the Inconel 718 and Nitronic 60 specimens exhibited much less surface roughening and no pitting/cratering compared to equivalent exposures for

Table 2

Comparison of weight loss (mg) for exposure in Hg at 25 °C for 60 min and for the sum of three consecutive exposure periods of 60 min

Material/condition	Density (g/cm^3)	Hardness	60 min at 25 °C	180 min at 25 °C
316LN, annealed	8.00	HRB 55–60	7.36, 7.68, 8.05	34.8 (b)
316LN, 50% cold worked	8.00	HRC 30–35	1.90, 1.71, 0.60	5.54 (a)
Inconel 718, annealed	8.23	HRB 72–82	2.11, 2.68	11.20 (b)
Inconel 718, aged	8.23	HRC 42–45	1.85, 1.96	5.80 (a)
Nitronic 60, annealed	7.62	HRB 81–86	3.21, 3.36	7.68 (a)
Nitronic 60, 25% cold worked	7.62	HRC 22–31	1.63, 1.30	3.80 (a)
Stellite 3, cast	8.20	HRC 50–51	12.8, 11.8	16.4 (c)

Where available, replicate test results for 60 min exposures are given. For the 180 min exposures, ‘a’ denotes approximately constant weight loss in each of the three 60 min periods, ‘b’ denotes increasing weight loss, and ‘c’ denotes decreasing weight loss.

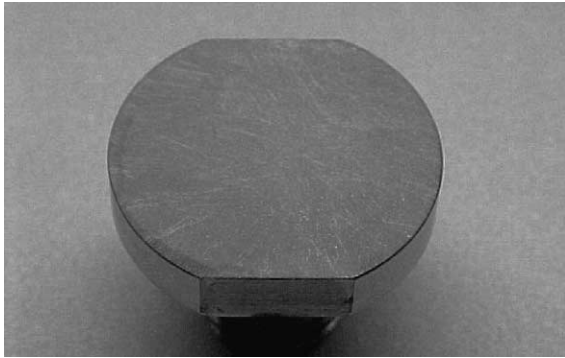

Fig. 11. Stellite 3 specimen exposed to cavitation conditions in Hg for 180 min at 25 °C.

annealed 316LN. Further, increasing exposure duration from 1 to 3 h did not substantially change the appearance or roughness of the surface – rather, weight change seemed to increase with a relatively fixed extent of surface roughness. A modest exception was the behavior of annealed 718, which revealed slightly increased surface roughness with increasing exposure time (see Fig. 12).

Further, while the cavitation erosion resistance at 25 °C of each of 50% cold-worked 316LN, aged Inconel 718, and 25% cold-worked Nitronic 60 are very similar, the hardness range encompassed by these materials is HRC 22–45. The softest material – annealed 316LN – performs slightly better than the Stellite 3 in 60-min exposures but is somewhat worse in the cumulative 180 min exposure. Other authors [15] have attempted to correlate cavitation damage with other mechanical properties and particularly with the strain energy (area under the stress–strain curve) from test materials. When stress–strain curves are not available, the strain energy can be crudely approximated [15] by the equation

$$\text{strain energy} = \{[\text{yield strength} + \text{ultimate tensile strength}]/2\} \times \text{elongation}, \quad (1)$$

Table 3

Comparison of weight loss (mg) for 60 min exposures at three different Hg temperatures

Material/condition	Density (g/cm ³)	Hardness	–5 °C	25 °C	80 °C
316LN, annealed	8.00	HRB 55–60	3.94	7.70	9.04
316LN, 50% cold worked	8.00	HRC 30–35	1.28	1.40	4.63
Inconel 718, annealed	8.23	HRB 72–82	4.78	2.40	3.53
Inconel 718, aged	8.23	HRC 42–45	4.36	1.91	2.74
Nitronic 60, annealed	7.62	HRB 81–86	5.56	3.29	4.49
Nitronic 60, 25% cold worked	7.62	HRC 22–31	2.19	1.47	0.98
Stellite 3, cast	8.20	HRC 50–51	2.68	12.3	1.76

Value for 316LN are averages of several replicate tests at each temperature; values for other materials are averages of duplicate tests for 25 °C and single exposures for other each of –5 °C and 80 °C. Greater mass loss is associated with less resistance to cavitation erosion.

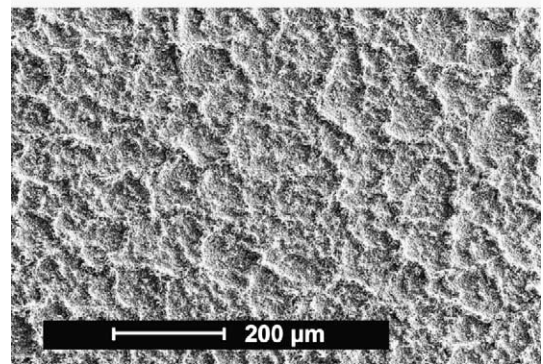
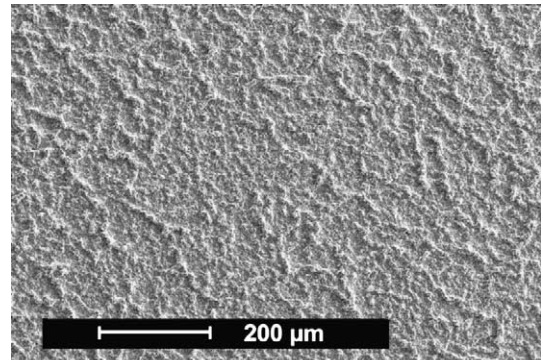

Fig. 12. Images of the surface of annealed Inconel 718 buttons sonicated for 1 h (top) and 3 h (bottom) in Hg at 25 °C.

where the yield strength is taken as the 0.2% offset value. These values are not known for the specific test materials reported here, and handbook values vary too much to make a meaningful estimate.

Table 3 summarizes the cavitation data for the alternate materials as a function of temperature and compares the results with those for 316LN. The data do not reveal a regular trend in resistance to cavitation in Hg as a function of temperature. While cavitation erosion resistance decreases with temperature for 316LN, three material/condition combinations exhibit maximum resistance (smallest weight loss) at 25 °C and one exhibits minimum resistance at 25 °C.

Nitronic 60 that is 25% cold-worked reveals a small but regular increase in resistance with increasing temperature.

In combination, the results for the alternate materials suggest that there are improvements available in cavitation erosion resistance compared to annealed 316LN, but 50% cold-worked 316LN performs very similarly to the alternate materials for which there is less information regarding other relevant target containment properties, such as irradiation damage behavior, fatigue properties, and general compatibility with Hg.

4. Conclusions

The cavitation erosion resistance of annealed 316LN stainless steel in Hg was examined using a vibratory horn and compared with the performance of 316LN in other conditions and several other materials. At 25 °C, annealed 316LN is quite susceptible to cavitation erosion as evidenced by relatively high wastage rates and the development of pitting/craters during extended exposures. Various surface modifications to the annealed 316LN proved to provide little practical improvement in cavitation erosion resistance, but 316LN cold-worked 50% exhibited significantly lower wastage rates and only minor pitting/craters for the conditions examined. Cavitation erosion resistance of 316LN was found to be a modest function of temperature – higher temperature corresponds to somewhat higher wastage – but literature information regarding this trend was mixed. Cavitation erosion of annealed 316LN in water was considerably less than for comparable conditions in Hg.

Cavitation erosion data for other materials/treatments at conditions identical to those for 316LN experiments indicated aged Inconel 718 is slightly superior to annealed Inconel 718, and that 25% cold-worked Nitronic 60 is slightly superior to annealed Nitronic 60 and all of these perform similarly to 50% cold-worked 316LN. Stellite 3 in the as-cast condition proved to have the least resistance of the materials examined. Clearly, increased hardness is associated with increased wear/cavitation resistance, but it is not a stand-alone factor to determine performance in Hg.

Acknowledgements

The authors would like to acknowledge the role of several helpful individuals. Materials for machining and testing were acquired from B. Riemer, C. McKamey, and D. Pinkston. R. Ogle and S. Lewis provided Industrial Hygiene advice and services for controlling Hg exposures. M. Donaty, C. Wynn, and W. Simpson

provided helpful discussions regarding the operation and physics of the vibratory horn. J. DiStefano provided helpful discussions and reviewed the manuscript. K. Choudhury and F. Stooksbury helped prepare the manuscript. The work was funded by the Spallation Neutron Source.

References

- [1] R.P. Taleyarkhan et al., Proceedings of the 2nd International Topical Meeting on Nuclear Applications of Accelerator Technology (AccApp98), Gatlinburg, TN, September 1998.
- [2] F. Moraga, R.P. Taleyarkhan, Proceedings of the 3rd International Topical Meeting on Nuclear Applications of Accelerator Technology (AccApp99), Long Beach, CA, 1999.
- [3] R.P. Taleyarkhan et al., Proceedings of the International Topical Meeting on Advanced Reactor Safety (ARS'97), Orlando, FL June 1997.
- [4] J.R. Haines et al., Summary of mercury target pitting issue, Spallation Neutron Source Technical Report SNS-101060100-TR0004-R00, April 2002.
- [5] M. Futakawa, H. Kogawa, R. Hino, Journal de Physique IV 10/p9 (2000) 237.
- [6] Standard test method for cavitation erosion using vibratory apparatus, ASTM G32-98, American Society for Testing and Materials, Philadelphia, PA, 1998.
- [7] S.J. Pawel, J.R. DiStefano, E.T. Manneschildt, Corrosion of alloy 718 in a mercury thermal convection loop, Oak Ridge National Laboratory Report, ORNL/TM-1999/323, December 1999.
- [8] R. Simoneau et al., Proceedings of the 7th International Conference On Erosion by Liquid and Solid Impact, Cambridge, UK September 1987.
- [9] S.J. Pawel, J.R. DiStefano, E.T. Manneschildt, J. Nucl. Mater. 296 (2001) 210.
- [10] S.J. Pawel, J.R. DiStefano, E.T. Manneschildt, Effect of surface condition and heat treatment on corrosion of type 316L stainless steel in a mercury thermal convection loop, Oak Ridge National Laboratory Report, ORNL/TM-2000/195, July 2000.
- [11] S.J. Pawel, J.R. DiStefano, E.T. Manneschildt, Effect of mercury velocity on corrosion of type 316L stainless steel in a thermal convection loop, Oak Ridge National Laboratory Report, ORNL/TM-2001/018, February 2001.
- [12] S.J. Pawel et al., Cavitation as a mechanism to enhance wetting in a mercury thermal convection loop, Oak Ridge National Laboratory Report, ORNL/TM-2001/086, May 2001.
- [13] R. Garcia, F.G. Hammitt, R.E. Nystrom, Erosion by Cavitation or Impingement, STM STP 408, American Society for Testing Materials, 1967, p. 239.
- [14] M.D. Kass et al., Tribol. Lett. 5 (1998) 231.
- [15] S.G. Young, J.R. Johnston, Erosion by Cavitation or Impingement, ASTM STP 408, American Society for Testing Materials, 1967, p. 186.